

SIDERISE RF cavity barriers and firestops for raised access floors

SIDERISE RF cavity barrier and firestop systems are the market leading compartmentation solutions for use in raised access floors.

Application

SIDERISE RF cavity barrier and firestop systems prevent the spread of fire and smoke, and reduce sound transmission, by sealing the voids between raised access floors and floor slabs.

The range includes options to either subdivide large uninterrupted cavities or to provide continuity of fire resistance when aligned underneath partitions. Across the range, these simple to install systems have been tested for fire performance, acoustic performance and for use as a plenum liner.

They have been designed as a one-piece system and afford easy cutting and installation.

Additionally, due to a unique method of manufacture, the products also offer unique vertical compression to allow tightness of fit.

Benefits

- Easy to install
- Fully qualified fire performance
- Fully qualified acoustic performance
- Suitable for use in voids heights up to 1000mm
- Suitable for use in air plenum applications
- Integral smoke barrier

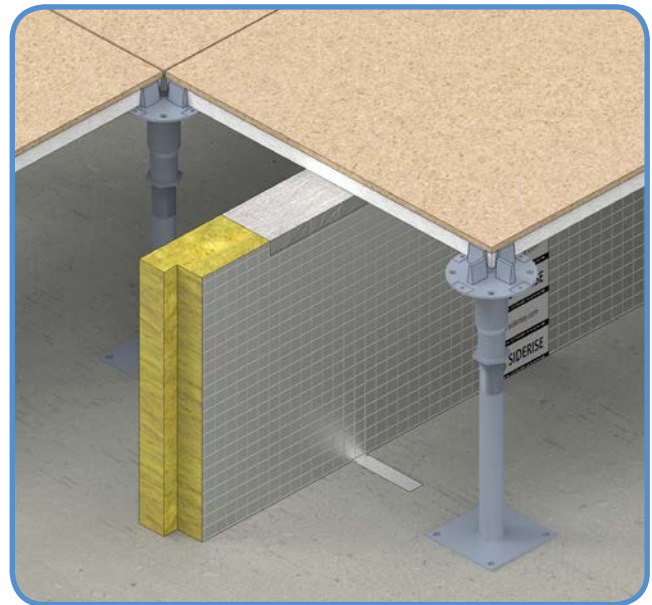

**Acoustic, fire and thermal
insulation specialists**

Product description

SIDERISE RF cavity barrier and firestop systems

comprise a non-combustible stone wool lamella core, which is faced on two sides with an impervious Class 0 aluminium foil, offering excellent resistance to the passage of smoke.

The product range is available in two versions, referenced as **CB** and **FS**.

SIDERISE RF-CB cavity barrier systems are used to subdivide uninterrupted voids in accordance with Building Regulations offering 30 minutes fire resistance. CB barriers are designed to suit individual floor void depths between 30mm and 600mm.

SIDERISE RF-FS firestop systems maintain continuity of fire resistance for installations aligned with fire rated partitions hence maintaining compartmentation. The 'FS' systems offers 60 to 120 minutes fire resistance. 'FS' barriers are designed to suit individual floor void depths between 30mm and 600mm, and up to 1000mm for high voids.

The materials are supplied with either simple **BJ** butt joints or an interlocking **RJ** rebated joint. Both options are available pre-cut to size or in sheets suitable for cutting on site. The rebated option, is recommended for acoustic and/ or air plenum applications.

The sheets are designed to be cut on site to suit individual floor void heights (plus a 10mm allowance to ensure a tight compression fit).

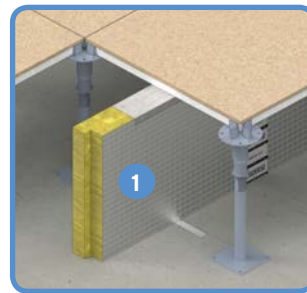

1 Product: RF-CB-RJ

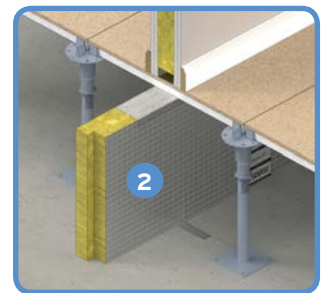

2 Product: RF-FS-RJ

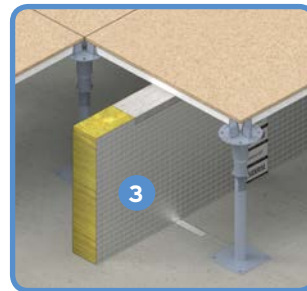

3 Product: RF-CB-BJ

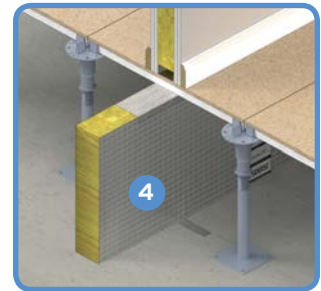

4 Product: RF-FS-BJ

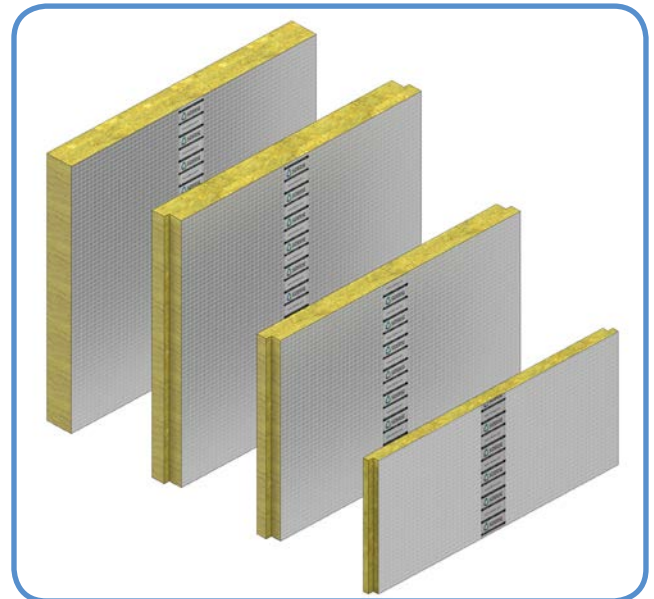

Fire performance

SIDERISE RF cavity barrier and firestop systems have been successfully tested and assessed to BS 476: Part 20 for up to 120 minutes fire resistance (integrity and insulation).

Each system option has been formally assessed by the Loss Prevention Council to meet the relevant performance ratings given in Table 1 below.

In terms of 'Reaction to Fire', the products provide the following:

Class 'A1', in accordance with EN13501-1 and EC Decision 96/603/EC

Class 'O', in accordance with BS 476 Part 6 & 7

Table 1 - Test report ref LPC 93001, pre-cut dimensions and fixing bracket requirements

Product Type	Barrier size				Fire performance		Void height limitation and bracket requirements			
	Thickness (mm)	Length (mm)	Rebated (mm)	Void height range (mm)	Integrity (mins)	Insulation (mins)	30 - 300 (mm)	301 - 400 (mm)	401 - 600 (mm)	601 - 1000 (mm)
RF-CB15 BJ	50	1200	None	30 - 600	30	15	None	2 no B110	2 no B355	N/A
RF-CB15 RJ	50	1175	25	30 - 600	30	15	None	2 no B110	2 no B355	N/A
RF-CB30 BJ	57	1200	None	30 - 600	30	30	None	None	2 no B355	N/A
RF-CB30 RJ	57	1175	25	30 - 600	30	30	None	None	2 no B355	N/A
RF-FS60 BJ	90	1200	None	30 - 600	60	60	None	None	2 no B355	N/A
RF-FS60 RJ	90	1175	25	30 - 600	60	60	None	None	2 no B355	N/A
RF-FS60HV BJ	120	1200	None	30 - 1000	60	60	N/A	N/A	N/A	2 no B355
RF-FS60HV RJ	120	1175	25	30 - 1000	60	60	N/A	N/A	N/A	2 no B355
RF-FS120 BJ	120	1200	None	30 - 600	120	120	3 no B110	3 no B110	N/A	N/A
RF-FS120 RJ	120	1175	25	30 - 600	120	120	3 no B110	3 no B110	N/A	N/A

Compliance

SIDERISE RF systems comply with the following Building Regulations, National Standards and Design Guides:

England and Wales: The Building Regulations 2000, Approved Document B - Fire Safety

Scotland: Technical Handbooks 2013 Non Domestic - Fire

Northern Ireland: Building Regulations (Northern Ireland) 2012, Guidance: Technical Booklet E Fire Safety

PSA: Method of Building Performance Specification - Platform Floors (Raised Access Floors), MOB PF2 PS/SPU

LPC: The LPC Design Guide for the Fire Protection of Buildings: A Code of Practice for the Protection of Business, The Fire Protection Association, 2000

Verification of fire performance and specific project advice is available upon request. Please contact: interiors@siderise.com

Acoustic performance

The installation of **SIDERISE RF systems** substantially enhances the 'room-to room' sound reduction of raised access floors which form a continuous common void under adjacent areas. This invariably results in improved speech privacy and greater control of disturbance from intrusive noise.

The excellent acoustic performance of the RF material is due to the unique internal construction of the stone wool lamella core. Also, the rebated overlap joints, foil facings and the additional sealing of the vertical joints with foil tape all serve to provide improved air tightness.

Based on laboratory tests to determine airborne sound transmission in accordance with BS EN ISO 140-3 : 1995, BS 2750 : Part 3 : 1995 on a variety of **SIDERISE RF systems** the following Weighted Sound Reduction Index (Rw) values can be used: as shown in table 3 below. Sound Research Laboratories Limited test report no. : C/99/5L/7743/1 refers

Actual performance will be dependent on a number of factors including the design, choice of materials and degree of fit between components.

For raised access floor systems requiring higher 'cross-talk' values i.e. approx. 45+dB, the improvement in 'cross-talk' value may be limited by other factors, including flanking transmission, leakage through M&E systems etc.

However, for installations offering a reduced 'cross-talk' performance, such as installations with frequent service openings, larger improvements can be effected by the installation of the RF before reaching limiting values. In such instances, improvements up to 20dB may be possible.

Fig 1 - Sound transmission path

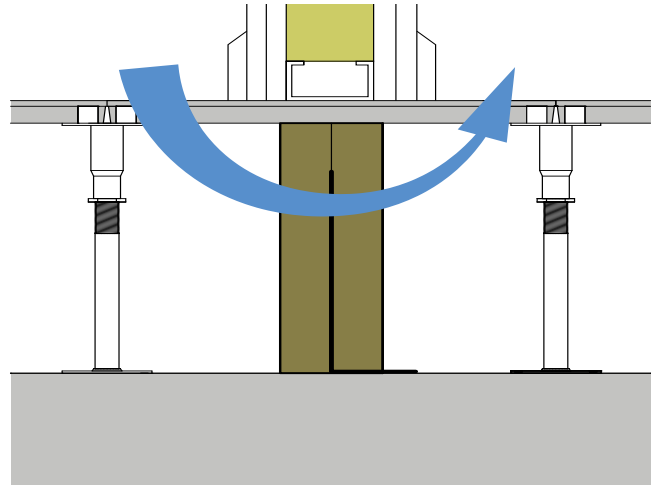

Table 2 - Acoustic performance

Weighted Sound Reduction Index		
Product Type	Thickness (mm)	Rw (dB)
RF-CB15 RJ	50	17
RF-CB30 RJ	57	19
RF-FS60 RJ	90	23
RF-FS60HV RJ	120	25
RF-FS120 RJ	120	25

Installation recommendations

1 Void height

For all installations, the void height should be measured and a +10mm compression factor allowed.

The single components are simply laid end to end on the structural floor to form a continuous barrier to fire and smoke. The correct size units are placed in position ensuring that the joints are pushed tightly together.

The height of the material can be trimmed on site using a sharp serrated knife providing the compression allowance is maintained.

2 Fixing brackets

Where required, fixing brackets are impaled centrally into the base of the barrier from alternate sides at nom. 600mm centres to provide stability. If required, the brackets can be mechanically fixed or bonded to the floor.

3 Foil tape

To assist in installation and maintain the integrity of the smoke barrier vertical joints can be taped with **SIDERISE foil tape** - FT 120/45.

It is further recommended that **SIDERISE foil tape** is applied continuously along the top of the run of fire barriers and at each vertical end joint. This will effectively secure the individual RF barriers to form one stable unit.

4 Plenum application

Being impervious, the integral reinforced Class 0 foil facings act as an effective barrier to air leakage.

When the RF-FS product is in place, the vertical joints between the products and interfaces with floors can be sealed with **SIDERISE foil tape** - FT 120/45 presenting an effective sealed construction suitable for plenum lining applications.

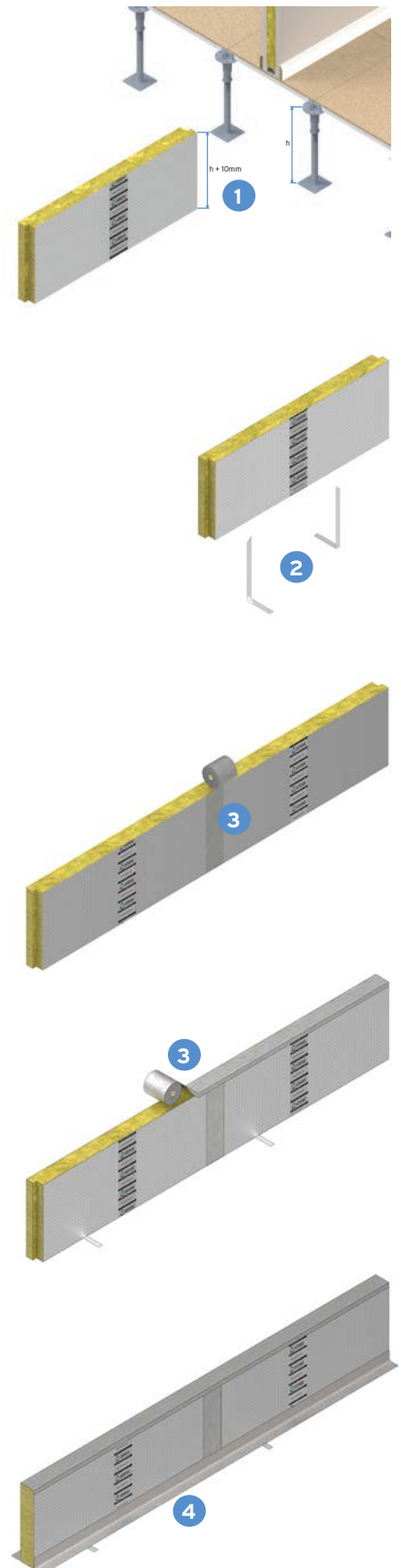

Cavity barrier installation: RF-CB-RJ-01-A

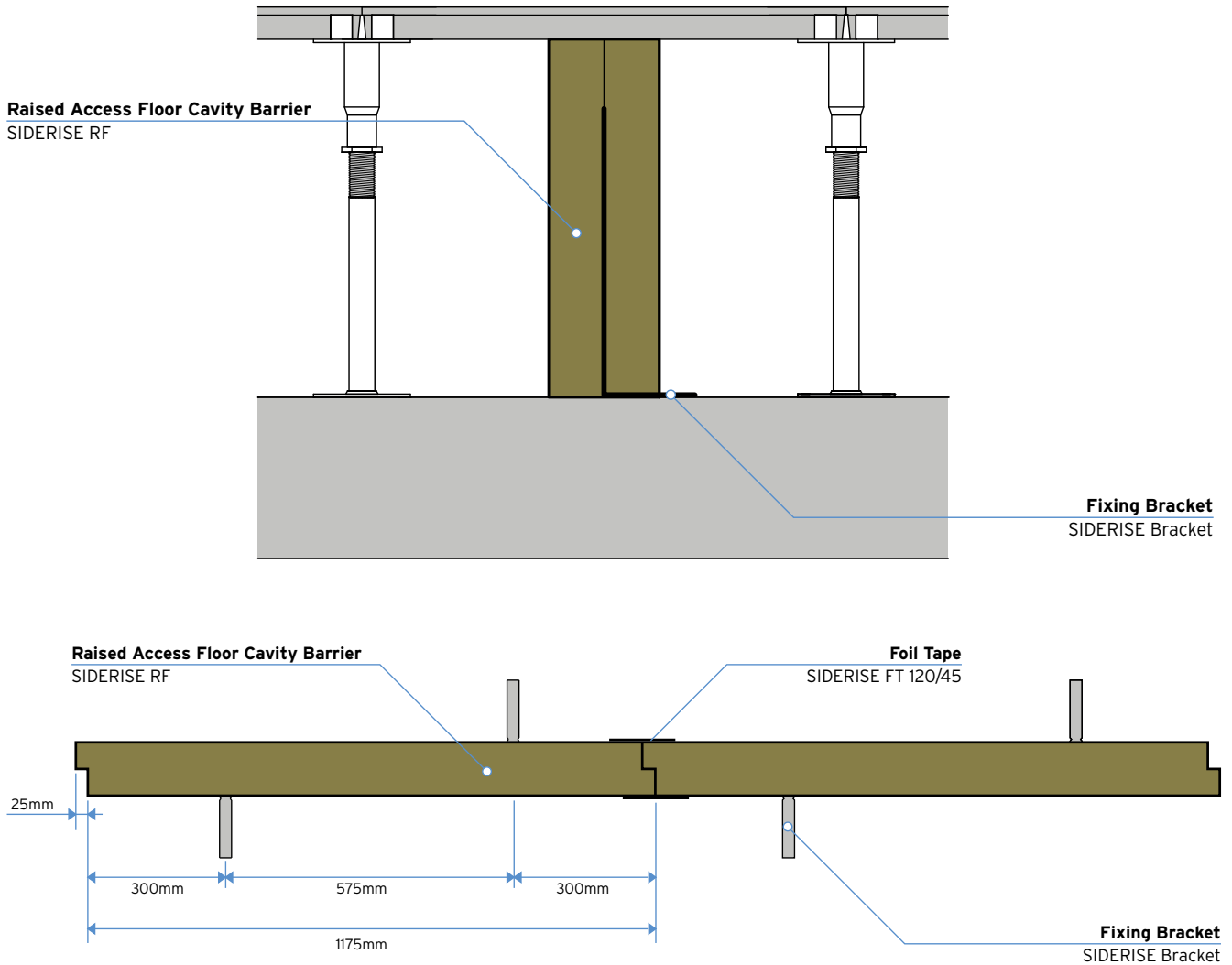

Products used

- 1 SIDERISE RF-CB-RJ cavity barrier for raised access floors
- 2 SIDERISE foil tape: FT 120/45
- 3 SIDERISE bracket

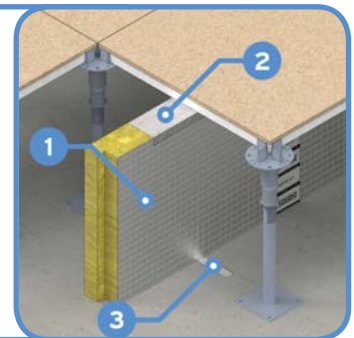

Firestop installation: RF-FS-RJ-02-A

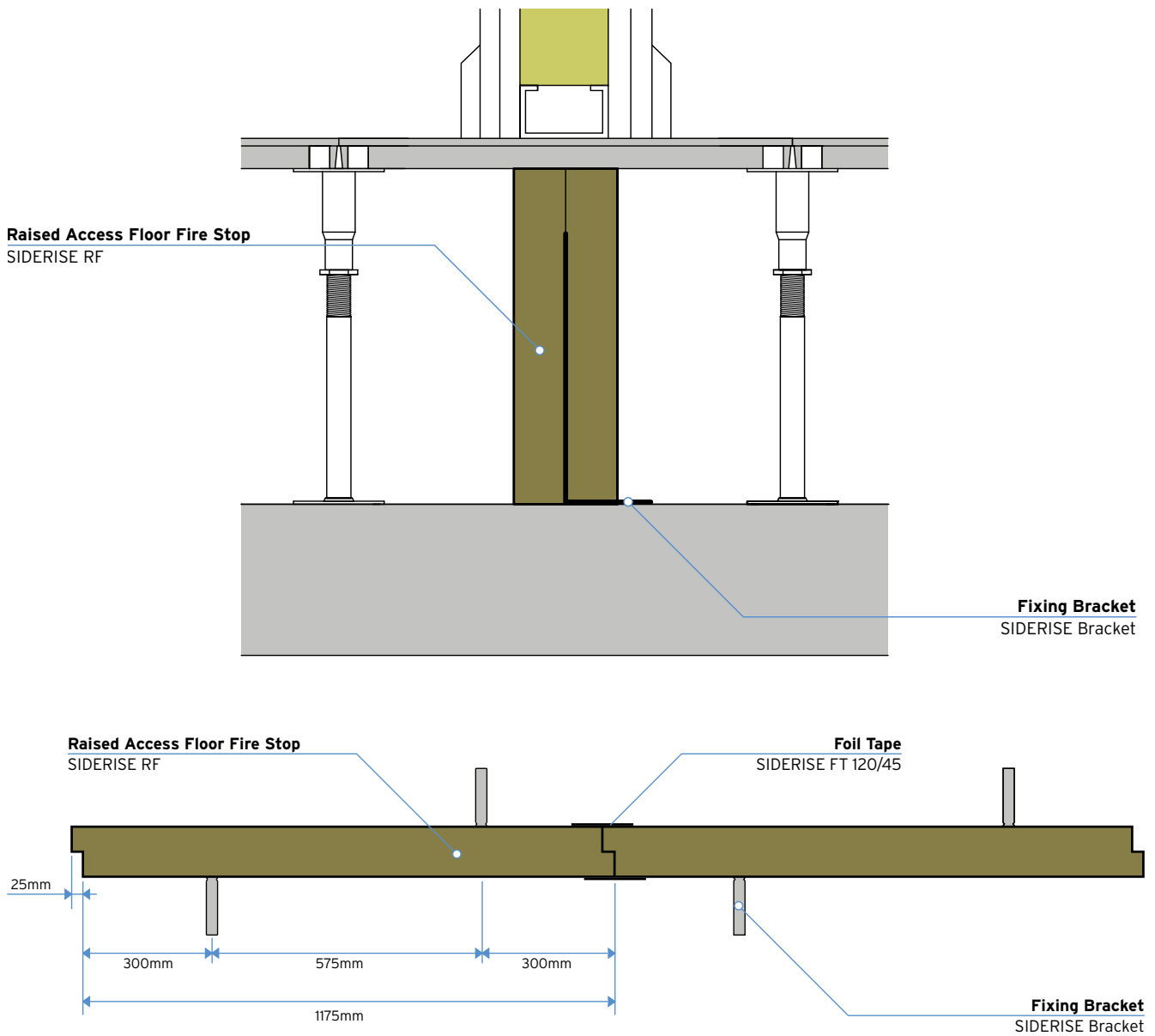

Products used

- 1 SIDERISE RF-FS-RJ firestop for raised access floors
- 2 SIDERISE foil tape: FT 120/45
- 3 SIDERISE bracket

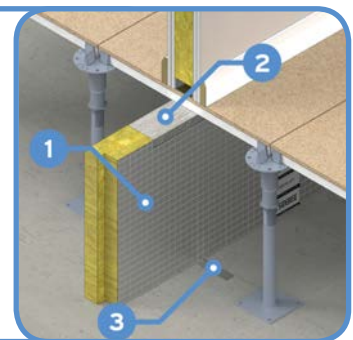

Cavity barrier installation: RF-CB-BJ-03-A

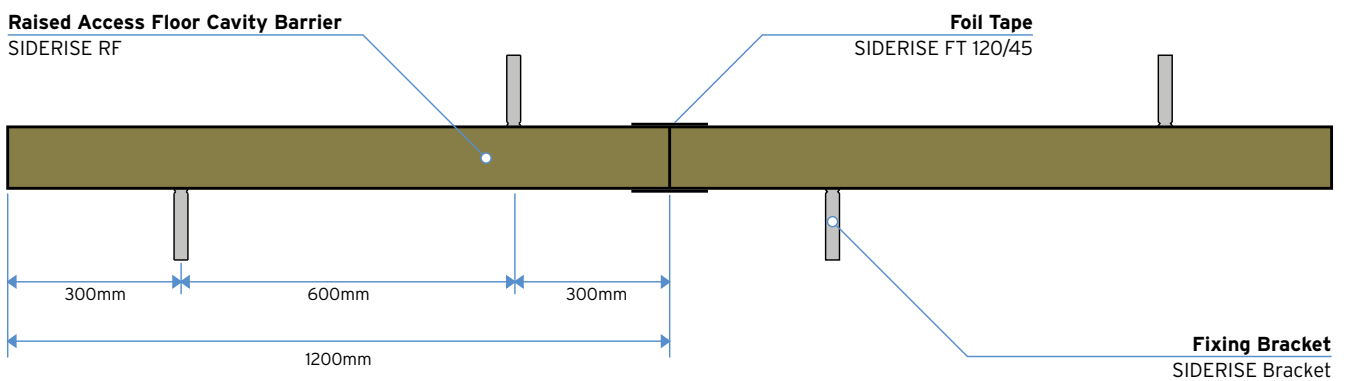
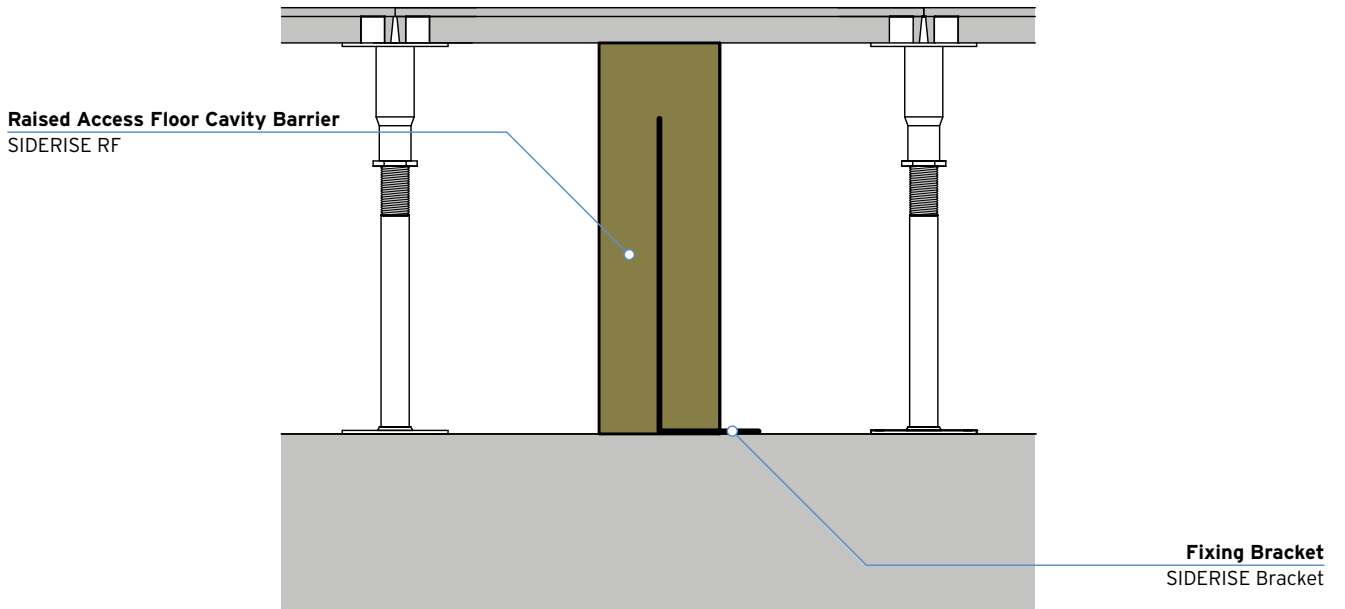

Products used

- 1 SIDERISE RF-CB-BJ cavity barrier for raised access floors
- 2 SIDERISE foil tape: FT 120/45
- 3 SIDERISE bracket

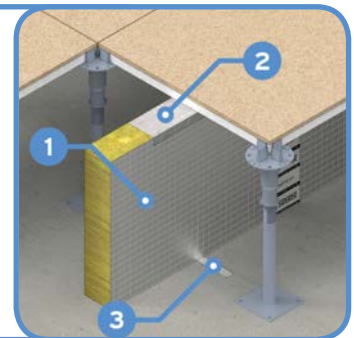

Firestop installation: RF-FS-BJ-04-A

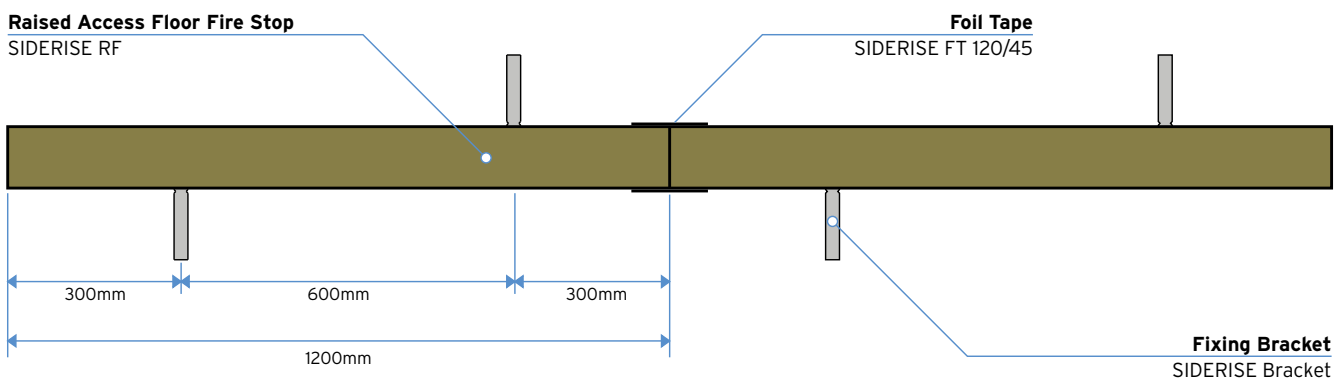
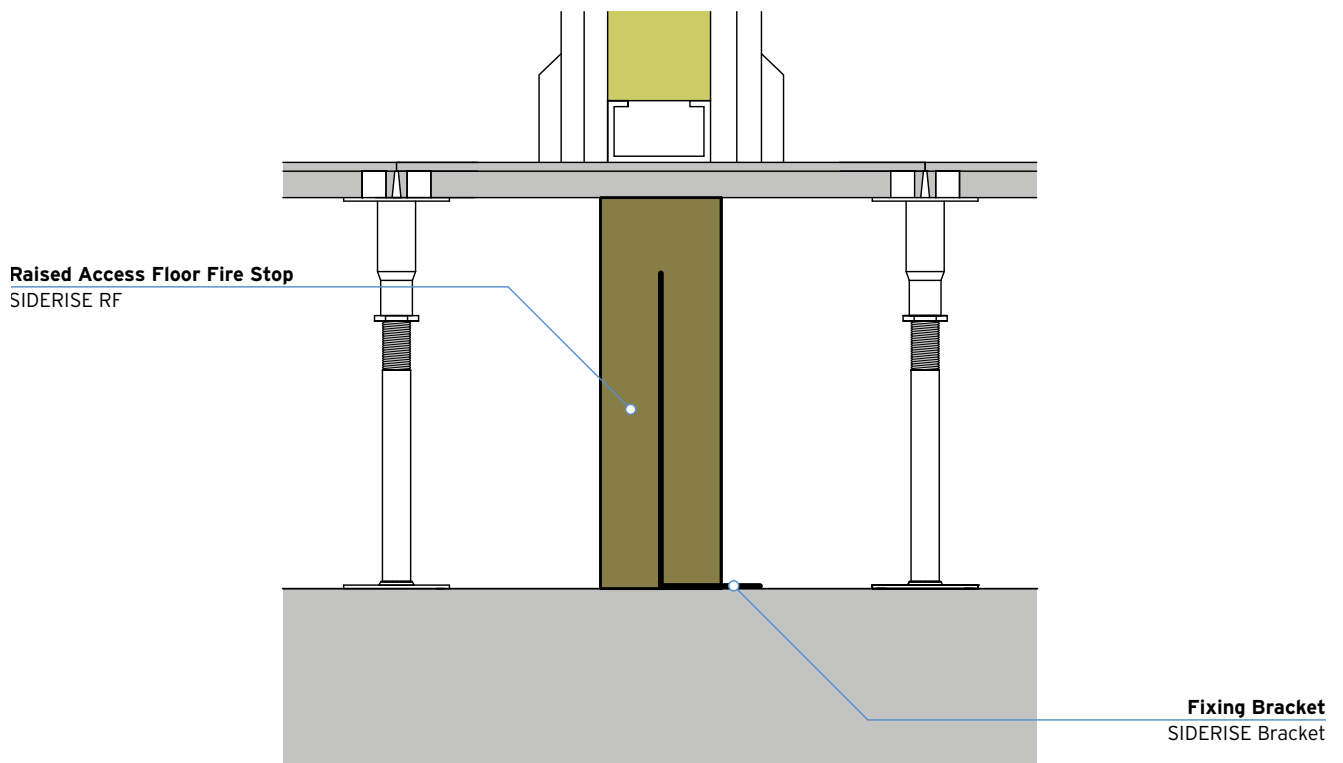

Products used

- 1 SIDERISE RF-FS-BJ firestop for raised access floors
- 2 SIDERISE foil tape: FT 120/45
- 3 SIDERISE bracket

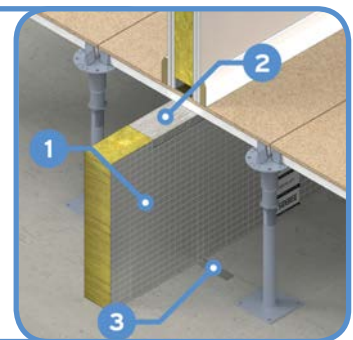

Service penetrations

Fire spread and limitation of damage is principally achieved by compartmentation. These compartments are bounded by fire resistant elements - including **SIDERISE RF-FS firestop**.

However, in practice, the many services required for buildings use and operation mean that these elements are breached to permit access for services. The gaps around the penetrations must therefore be sealed so that the fire integrity of the element is retained.

SIDERISE has tested the compatibility of their range of fire stopping systems, within the RF systems. Ad-hoc test FC 149.

A comprehensive range of complementary sealing systems are available which can be readily installed to provide appropriate sealing methods according to the type of penetration.

Treatment of penetrations

Standard RF systems can be readily treated to accommodate small to large obstructions such as PVC pipes, cable trays and ductwork.

Limitations:

It is recommended that services are fitted through the system only if they have been shown by test to be suitable for this type of vertical seal system and for the required rating.

The services may occupy no more than 50% of the barrier face area and must not be closer than 50mm to any edge of the RF seal.

The services must be supported adjacent to the seal on both sides so that the weight of the services is not taken by the RF system.

Irrespective of the void height, wherever the RF barrier is penetrated by services, fixing brackets must be used. These must be mechanically secured or bonded to the structural floor to maintain the stability of the assembly.

For information and advice regarding the treatment of service penetrations please contact interiors@siderise.com

Health and safety

There is no hazard statement associated with this material. Stone wool is not classified as dangerous according to EU Directives 67/548/EEC and 1999/45/EC and its amendments (Regulation (EC) No 1272/2008) on classification, labelling and packaging of substances and mixtures. A Safety Data Sheet (SDS) is available upon request.

Environmental

SIDERISE RF cavity barriers and firestops for raised access floors are environmentally friendly.

- They contain no Volatile Organic Compounds (VOCs) and no very Volatile Organic Compounds (vVOCs).
- Zero Ozone Depleting Potential
- Zero Global Warming Potential
- Recyclable

Technical specification

Form supplied	Sheet BJ: 1200mm x 1200mm x thickness; Sheet RJ: 1200mm x 1175mm x thickness Pre-cut strips 1200mm x (cavity + 10mm compression) x thickness (See Table 1.)
Colour	Silver, with coloured identification tape centrally located on product
Finish	Bright aluminium foil
Density	Nominal 80Kg/m ³
Thermal conductivity	$\lambda_{20} = 0.04$ w/mK
Cavities	30mm to 1000mm, for voids over 1000mm please contact interiors@siderise.com
Fire resistance	15 to 120 minutes EI (insulation / integrity)
Reaction to fire	Class 'A1', Class 'O'

Products required

The following SIDERISE products are available.

- **SIDERISE RF cavity barrier and firestops for raised access floors** - sheet or pre-cut strip options
- **SIDERISE foil tape:** FT 120/45
- **SIDERISE fire and acoustic gap sealant**

Ordering

When ordering please:

- Indicate contract title and location of project.
- Specify product type required, e.g. sheet form, **BJ** butt joints or **RJ** rebated joints.
- Specify fire rating or thickness required.
- Specify void height or schedule of sizes for each product type.
- Confirm total linear metres required for each size.
- Specify bracket type and quantity required
- Specify foil tape quantity requirement: FT 120/45 (or RF/SFT100/10 for a high specification tape).
- Order **SIDERISE fire and acoustic gap sealant** 310ml cartridge

Additional information

The following information is available upon request or via download from the website:

- NBS Specification Clause
- Safety Data Sheet
- Cutting and Installation instructions

Technical advice

For further information please contact our technical team at the address below.

**Developing insulation solutions
for over 40 years**

